

AGC Driver

The AGC driver, a feedback amplifier, operates a broad range of resonant optical scanners and resonant optical choppers at their natural frequency. The AGC driver has an Automatic Gain Control circuit, which automatically regulates the motion amplitude of the resonant device. It improves amplitude stability by approximately 10 times compared to the unregulated drivers and provides precise control for a wide temperature range. The driver is available as a cased driver operating from line voltage or as a board level driver without the enclosure and power supply.

FEATURES AND ADVANTAGES

- Automatically regulated feedback amplifier
- Improves the amplitude stability of the device
- Provides sine wave and TTL square wave reference signals
- Trim pot for adjustment of 180° of reference signal phase
- Trim pot for amplitude adjustment

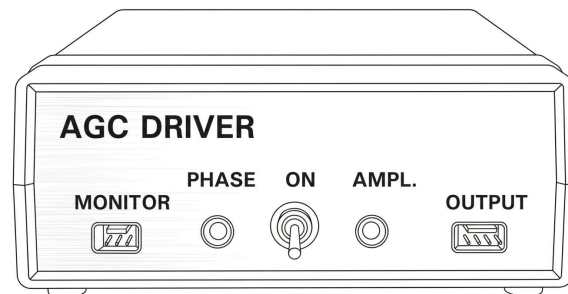

AGC Driver

SPECIFICATIONS

Input voltage	±12V to ±15V DC, 0.3 amps max for AGC-PC; 110V AC or 220V AC, 10W for AGC-110 and AGC-220
Frequency range	5 Hz to 20 kHz
Amplitude regulation	0.01% or better typical (depending on temperature range)
Amplitude adjustment range	10% to 100% of full amplitude
Reference output	Sine and TTL level square wave
Phase adjustment range	180°
Voltage control input	0V to 5V DC input into 10KΩ for the AGC-VC
Power connector	7478 series 3-pin male Molex connector for AGC-PC; 3-pin male IEC-320-C14 connector for AGC-110 and AGC-220
Operating temperature	0 to 65 °C

OPTIONS

AGC-PC	Board level driver requiring an external ±12V to ±15V DC power supply.
AGC-110 or AGC-220	Cased driver (5.3" × 5.3" × 2") operating from a line voltage of 110V AC or 220V AC.
AGC-110/220	Cased driver (5.3" × 5.3" × 2") with selector switch for operating from a line voltage of 110V AC or 220V AC.
-VC	Driver that regulates and controls the amplitude of the resonant device via external DC voltage (0 to 5V).

CONTROLS

- Both sine wave and TTL level square wave are provided as reference signals.
- A phase trimpot permits the user to adjust the phase of the reference signals with respect to the position of the mirror or the vane. The adjustable range is 180°.
- An amplitude trimpot provides amplitude adjustment in the range of 20% to 100% of the full amplitude.

AGC Driver

DRAWINGS

AGC-PC

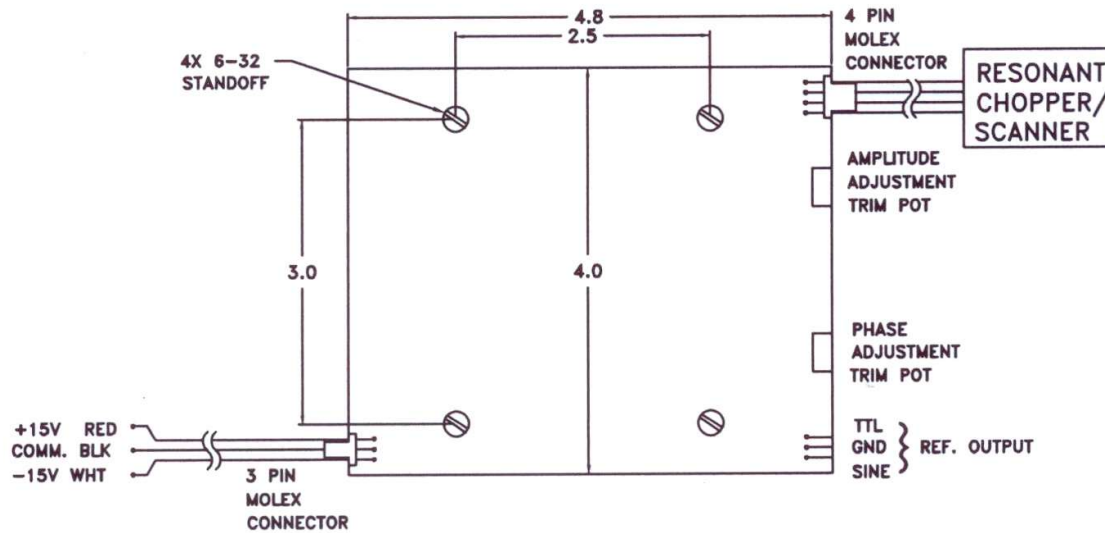

AGC-VC-PC

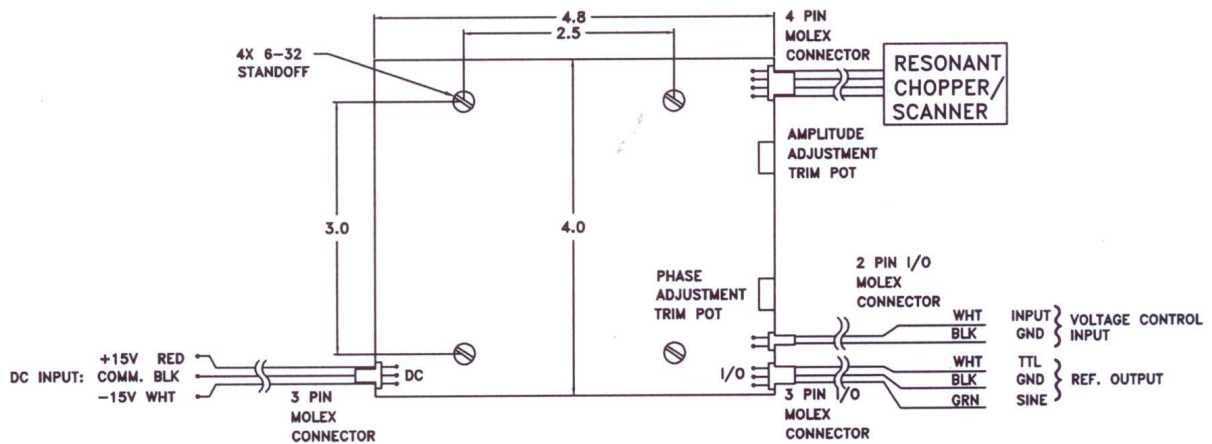

AGC Driver

AGC-110 and AGC-220

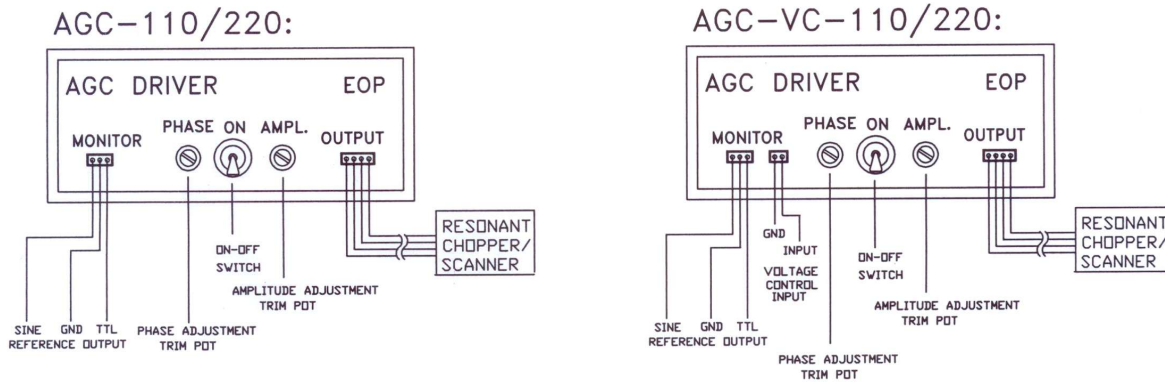

ORDERING INFORMATION

TYPE [AGC-110, AGC-VC-110, AGC-220, AGC-VC-220, AGC-110/220, AGC-VC-110/220, AGC-PC, AGC-VC-PC], per customer specifications.

AGC Driver

IMPORTANT NOTICE AND DISCLAIMER

ELECTRO-OPTICAL PRODUCTS CORP. (“EOPC”) PROVIDES TECHNICAL AND RELIABILITY DATA (INCLUDING DATA SHEETS), DESIGN RESOURCES (INCLUDING REFERENCE DESIGNS), APPLICATION OR OTHER DESIGN ADVICE, WEB TOOLS, SAFETY INFORMATION, AND OTHER RESOURCES “AS IS” AND WITH ALL FAULTS, AND DISCLAIMS ALL WARRANTIES, EXPRESS AND IMPLIED, INCLUDING WITHOUT LIMITATION ANY IMPLIED WARRANTIES OF MERCHANTABILITY, FITNESS FOR A PARTICULAR PURPOSE OR NON-INFRINGEMENT OF THIRD-PARTY INTELLECTUAL PROPERTY RIGHTS.

These resources are intended for skilled developers designing with EOPC products. You are solely responsible for (1) selecting the appropriate EOPC products for your application, (2) designing, validating and testing your application, and (3) ensuring your application meets applicable standards, and any other safety, security, regulatory or other requirements.

These resources are subject to change without notice. EOPC grants you permission to use these resources only for development of an application that uses the EOPC products described in the resource. Other reproduction and display of these resources is prohibited. No license is granted to any other EOPC intellectual property right or to any third party intellectual property right. EOPC disclaims responsibility for, and you will fully indemnify EOPC and its representatives against, any claims, damages, costs, losses, and liabilities arising out of your use of these resources.

EOPC’s products are provided subject to EOPC’s Terms of Sale or other applicable terms available either on eopc.com or provided in conjunction with such EOPC products. EOPC’s provision of these resources does not expand or otherwise alter EOPC’s applicable warranties or warranty disclaimers for EOPC products.

EOPC objects to and rejects any additional or different terms you may have proposed.

Mailing Address: Electro-Optical Products, Corporation, 939 S. Andreasen Drive, Escondido, CA 92029, USA

Copyright © 2025, Electro-Optical Products, Corporation